



Butterfly valve RX® fig. 706X lug type with ISO top flange

full lug type butterfly valve with threaded holes and rubber seat, suitable for water, neutral liquids and HEVAC and suitable for automation

Material body	: ductile cast iron (GJS 400-15)
Material disc	: stainless steel 316 (GX5CrNiMo19-11-2)
Material shaft	: stainless steel 316 (X5CrNiMo17-12-2)
Material spring ring	: stainless steel
Material circlip	: stainless steel (65Mn)
Material seat	: EPDM
Material bushing	: glass fibre reinforced PTFE with graphite coating
Material O-ring	: NBR
Process connection	: installation between (welding neck) flanges - up to DN150; PN10/16 - DN200 up to DN300; PN10
Overall length	: according to EN 558, table 1/20 (formerly DIN 3201-K1)
ISO top flange and spindle	: as per ISO 5211
Spindle bearing	: - upper spindle; three bearing bushes - lower spindle; one bearing bush
Maximum operating pressure	: - up to DN150; 16 bar - DN200 up to DN300; 10 bar
Temperature range	: -20 °C to +120 °C
Body coating	: epoxy
Tightness testing	: 100% bidirectional leak tight (table A5, Rate A) according to EN12266-1 (formerly DIN 3230)
Other characteristics	: - cast "ears" with threaded holes - lengthened neck for insulation - anti-blow out spindle - reinforced, integrated (U-type) seat with wide flange gaskets with extra sealing groove on both sides - connection upper spindle with disc by a precise "spline" connection - suitable as dead-end service valve with counter flange
Operation	: - handle; see fig. 706X/MH - gearbox; see fig. 706X/WK - pneumatic; single-acting, spring return, see fig. 706X/ASR - pneumatic; double-acting, see fig. 706X/ADA - electric; see fig. 706X/ER, fig. 706X/VS and fig. 706X/VT

*Larger sizes on request
Butterfly valves in accordance with PED 97/23/EC*

The information provided in this document is for general information purposes only and does not constitute advice. ERIKS shall not be liable for any damages resulting from the use of this document, including but not limited to damages caused by any incorrectness or incompleteness of the provided information, unless such damage is the result of any willful misconduct or gross negligence on part of ERIKS.

For more information, a quotation or an order please contact one of our specialists on number +31 (072) 514 18 00

ERIKS bv • P.O. box 280 • 1800 BK Alkmaar • phone (072) 514 15 14 • fax (072) 515 56 45 • info@eriks.nl • www.eriks.nl

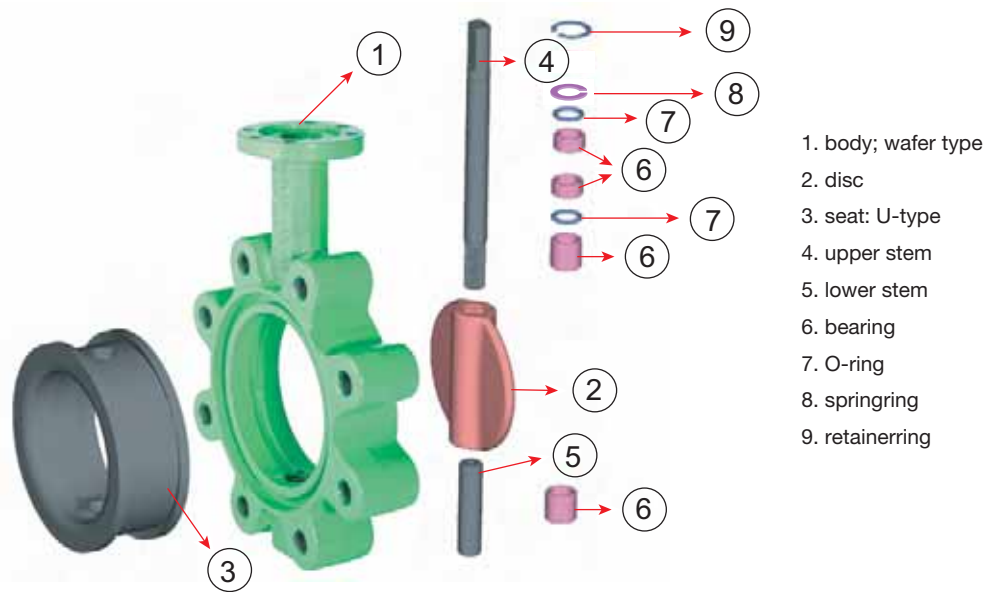

Tabel 1: Dimensions fig.706X

DN	Butterfly valve							Spindle		Top flange ISO 5211							Torque	Weight
	A	B	C	D	H	ØDk	nxM	E	G	ISO	a	b	f	nxØy	h1	Ød2		
	mm	mm	mm	mm	mm	mm		mm	mm		mm	mm	mm	Mm	mm	mm		
50	141	62	43	93	45	125	4xM16	19	11	F07	90	70	12	4x9	3	55	20	3,1
65	154	72	46	104	57	145	4xM16	19	11	F07	90	70	12	4x9	3	55	25	3,6
80	160	87	46	121	73	160	8xM16	19	11	F07	90	70	12	4x9	3	55	25	5,0
100	178	106	52	152	96	180	8xM16	19	11	F07	90	70	12	4x9	3	55	30	7,0
125	191	121	56	178	116	210	8xM16	19	14	F07	90	70	12	4x9	3	55	40	9,5
150	201	138	56	200	147	240	8xM20	19	14	F07	90	70	12	4x9	3	55	65	10,5
200	247	174	60	260	194	295	8xM20	25	17	F10	125	102	12	4x11	3	70	140	16,5
250	280	207	68	315	242	350	12xM20	40	22	F10	125	102	18	4x11	3	70	200	29,0
300	324	250	78	374	292	400	12xM20	40	22	F10	125	102	18	4x11	3	70	380	46,0

* Torques are based on liquid and measured on opening of the butterfly valves.
Before selecting an actuator a safety percentage of 30% must be added to the torques in the table.

Tabel 2: K_{v(s)}-values for specified disc opening angles

DN	10°	20°	30°	40°	50°	60°	70°	80°	90°
50	-	0.8	5.3	12	24	45	79	98	100

* the coefficient of flow K_{vs} for a valve is the flow of water in m³/h measured at 4°C (Density = 1,000 kg/m³) which for a pressure loss of 1 bar passes through the valve considered as entirely open

The information provided in this document is for general information purposes only and does not constitute advice. ERIKS shall not be liable for any damages resulting from the use of this document, including but not limited to damages caused by any incorrectness or incompleteness of the provided information, unless such damage is the result of any willful misconduct or gross negligence on part of ERIKS.

For more information, a quotation or an order please contact one of our specialists on number +31 (072) 514 18 00

ERIKS bv • P.O. box 280 • 1800 BK Alkmaar • phone (072) 514 15 14 • fax (072) 515 56 45 • info@eriks.nl • www.eriks.nl

Tabel 2: $K_{v(s)}$ -values for specified disc opening angles

DN	10°	20°	30°	40°	50°	60°	70°	80°	90°
65	-	2.1	9.3	23	42	78	142	208	219
80	-	4.5	18	42	76	133	239	391	433
100	-	8.3	34	76	134	227	412	699	787
125	-	13	59	127	223	365	651	1.147	1.275
150	-	71	96	195	335	544	931	1.572	1.844
200	-	95	180	344	576	921	1.517	2.588	3.265
250	17	131	262	501	840	1.351	2.308	4.050	4.261
300	40	240	326	633	1.065	1.749	3.180	5.797	7.845

* the coefficient of flow K_{vs} for a valve is the flow of water in m^3/h measured at 4°C (Density = 1,000 kg/m^3) which for a pressure loss of 1 bar passes through the valve considered as entirely open

